

EFFICIENCY OF LINEAR ACCELERATORS FOR APPLIED AIMS

A.G. Lymar, E.N. Sokolenko, **N.A. Khizhnyak**

National Scientific Center, Kharkov Institute of Physics and Technology,
Akademicheskaya St., 1, 61108, Kharkov, Ukraine

E-mail: khizh@khizh.kharkov.ua

As it is well known the accelerator efficiency as a whole η is the product of the efficiency of an accelerator itself η_a and the efficiency of its power feed system η_f : $\eta = \eta_a \cdot \eta_f$. There are many papers in which the value of η_a is considered but the value of η_f is studied worse. This paper is the review of the works concerning the increase of η_f in dependence on a chosen high-frequency power system of the accelerator. In this case both linear electron accelerators and proton radio-frequency accelerators are considered. In initial versions the accelerator was considered as a system consisting of two subsystems: i.e. the power supply system and the accelerating structure itself. It was supposed that η_f is determined by a product of the generator efficiency multiplied by the feeding system efficiency. Separately created was r.f. generator with a high electronic efficiency and the feeding system was improved. Last time the tendency appeared when the feeding system was degenerated practically and r.f. power system of the accelerator was the component structure of the accelerator itself. Let consider the evolution of r.f. power system on examples of electron and proton accelerators.

PACS number: 29.17.+w

1 LINEAR ELECTRON ACCELERATORS

In single-section TW accelerators one commonly uses the initial power scheme: generator - feeding line - a wave transformers - accelerator - indirect transformer - feeding line - matching charge (Fig. 1, a). Both the beam load of the accelerator, and own losses of r.f. power in the accelerating structure result in decreasing the r.f. power flow, and, consequently, in decreasing the accelerating field intensity, i.e. the acceleration rate. The power lost in walls of the accelerating structure as well as the power lost in feeding lines, are inevitable losses in the system; the power consumption for acceleration of a beam is a useful capacity. Therefore, the ratio of the power consumption for beam acceleration to the generator power can be varied in some limits. So, even in work [1] the scheme of recuperation of r.f. energy was proposed to apply the unused rest energy again to the input of the accelerating structure. Under definite conditions all the energy from the generator was used only for inevitable heat losses in the system and for beam acceleration, it was the more optimal system of power supplying to the single-section accelerator from the generator. As a discharging device in the first accelerators the waveguide circular bridge (Fig. 1b) dividing equally the power from the arm I between arms II and IV was used. Other relations between the powers going to shoulders II and IV are possible, but technical realization of such bridges is much more complex.

In multisection high-energy accelerators, feeding from several r.f. power generators, the scheme shown in Fig. 1 is formed and used in all places. Each accelerating section is power supplied by one amplifier W_i (i is the number of section) and all power amplifiers are supplied by one generator G. The power from the generator is supplied parallel to the accelerator along the waveguide line L and at definite distances from the generator, the part of it is tapped for excitation of every

power amplifier W_i .

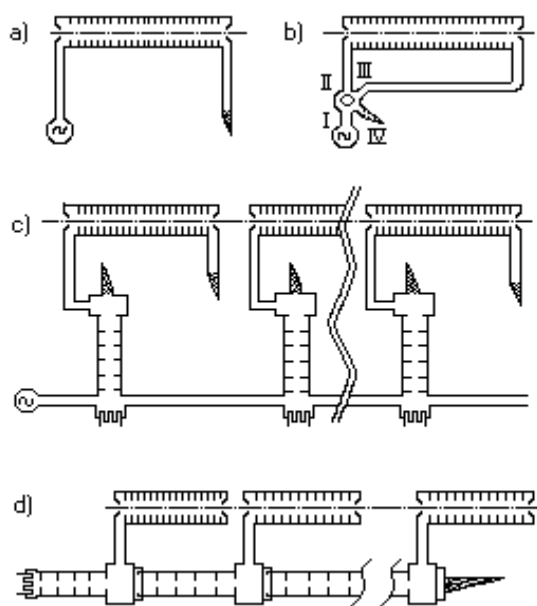

Fig. 1. Power system of the linear electron accelerator.

- a) – Single electron accelerator: ~ – r.f. power generator; ∇ – matching load.
- b) – Single-section electron accelerator and the power system with r.f. energy recuperation.
- c) – Multisection linear electron accelerator. Each section is supplied by its amplifier, and all the amplifiers are powered by its driving generator.
- d) – Unrealized system for power supply to the multisection electron accelerator from the parallel waveguide section of amplifiers.

This power amplified to the operating value, moves to the input of the corresponding accelerating section where the subsequent acceleration of electron bunches

up to high energies is realized. Thus, the frequency of the driving generator is the general operating frequency of all the accelerator as a whole and phase shifters in feeder tracts of each accelerating section permit to set the required initial phase for bunch accelerating at the input of the section.

All the multisection linear high-energy electron accelerators have such power schemes.

The evident improvement, which should increase the general efficiency of the accelerator, is described in the literature, but it was not realized in practice (Fig. 1d). The line of the generator is placed parallel to the accelerating section and consists of the general electron cathode and a subsequent chain of accelerating modulation sections, where the predetermined electron current, is additionally accelerated and modulated with a passive modulation system, passes through the resonator in which the energy of oscillations is taken off for the next section of the electron accelerator, and again enters the section of additional accelerating and driving of oscillations. The main problem has not been yet solved, i.e.: what number of additional accelerations the generator beam can hold before its quality decreases to the limited assumed value.

Note that for the acceleration rate of the order of 10 MeV/m already in the first section of the accelerator electrons achieve relativistic velocities and therefore the change of the total energy attained by the electron bunch in successive sections is regulated by the power amplifiers.

2 PROTON LINEAR ACCELERATORS

The proton acceleration has its own peculiarities. The proton mass is almost 2000 times higher than the electron one, therefore up to energies as high as 100 MeV the proton movement is nonrelativistic and in the limits of about 1 GeV it is weak relativistic. So, the proton velocity is determined by the intensity of the accelerating radio-frequency field, and in the initial part this velocity changes constantly, then the parameters of the accelerating structure also continuously change in synchronism with changes of the particle velocity. Therefore in a wide-range of energies the accelerating structure of the proton accelerator is non-uniform.

Even for the injection energy of 1 MeV ($\beta = 4.6 \cdot 10^{-2}$, where $\beta = v/c$ is the proton velocity- light velocity ratio) accelerating gaps will be of centimeters in size if the operating wavelength is of the order of 2 m. For such low particle velocities there are no effective electrodynamic structures therefore for ion acceleration one uses the resonators in which standing electromagnetic waves are excited. The first - in the world - resonator accelerating system (a resonator is on the axis and loaded with the drift tube shielding the particles being accelerated from the field action in the retarding phase) was built in 1946 in the Lawrence Berkley Laboratory (USA) by the American physicist L.U.Alvarez and called the Alvarez type accelerator. In 1950 in KPTI (now NSC KIPT) the first -in the USSR- linear proton accelerator was started and it was the Alvarez type accelerator. The Alvarez type accelerators were described very well in the litera-

ture and their radio-frequency power systems are of our interest, since these systems are connected directly with an accelerator construction. The original scheme of the power system (Fig. 2a), which could be suggested by the specialists in high-frequencies, was a classical one. In such a manner 20-30 MeV accelerators were built and, in further, power systems of proton accelerators were improved in different ways [2, 3].

In Fig. 2 the power system of the modern high- energy proton accelerator is presented. Note basic peculiarities of proton accelerator developments.

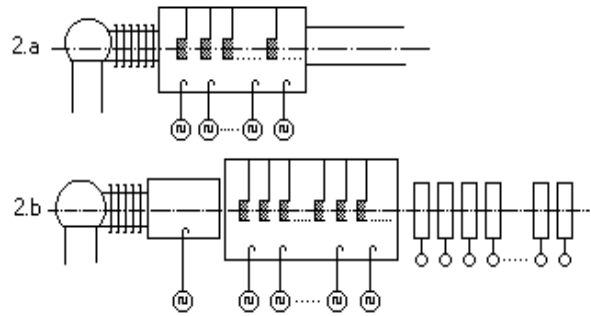

Fig. 2. Schemes of power systems of proton linear accelerators.

a) – Single-section proton accelerator.

b) – Proton accelerator with a buncher and resonator system after 100 MeV.

Decrease of the injection energy which was realized with using the initial accelerator part (IAP) built on the basis of other physical principles. The modern initial accelerator part widely practiced is the accelerator with homogeneous quadruple focussing (RFQ - radio-frequency quadruple). This accelerator is very effective for a quite small β assuming the energy of injection to 100 keV and even lower, but its acceleration rate is low, therefore it is used in the range of 100 keV+5÷7 MeV where the Alvarez system is yet not effective. For energies higher than 150 MeV the effectiveness of the Alvarez's system decreases and further one uses the accelerating structure of the type of the chain of various endovibrators.

Further different authors use the above variants of power systems, either using the cryogenic engineering to decrease heat losses in resonators, or multiple passing with the beam of the same accelerating structure (Fig. 2c, d).

The essential change of the value of η_f can be obtained in systems where one supposes deeper unity of the electron beam line (the initial chain of the accelerator as a source of a high voltage) with the channel of proton beam acceleration (of the secondary chain of the high-energy accelerator). Two variants of such an arrangement are known - they are the two-beam accelerator and the linear collective accelerator.

3 LINEAR COLLECTIVE ACCELERATORS

One of the first variants of the linear collective accelerator was suggested in 1974 and now it is developed

in the National Science Center “Kharkov Institute of Physics and Technology”.

The development of collective methods of ion accelerations realized in the Department of Accelerators of Heavy Particles, IPENMA NSC KIPT, has been oriented generally to the realization of the earlier proposed method of ion acceleration with spatial harmonics of charge density waves [4] in the mode of high pulse duration of the accelerated current, and to creation, in perspective, of high-current accelerators of continuous action for the applied aims.

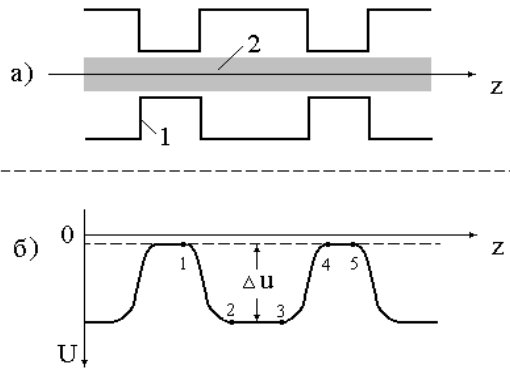

Fig. 3.

The idea of the supposed technique of ion acceleration can be described by means of Figs. 3a and 3b. In Fig. 3, a shown is the schematic of the section of the accelerating system (AS). It consists of an axial symmetric conducting screen 1 and an electron beam (EB) 2, coaxial with it, moving along the axis z . In Fig. 3, b the potential distribution on the axis of the system when the current value of EB does not equal to zero is represented. The potential of a screen equals to zero. The characteristic peculiarity of this potential distribution is the presence of potential wells for ions in the places where the screen is of a higher radius.

For ion moving in a positive direction along the axis z , the slope of the well between points 1 and 2 is accelerating one and when passing this slope the ion energy is increased by the value $e\Delta U$. To conserve in the acceleration period L this ion energy gain it is necessary to decrease the current value of EB to zero when ion passes this section 2-3. Then the potential on the axis of the system will be everywhere equal to zero and the moderating well slope will disappear. If then during ion

moving in the section 4-5 the current value of EB is turned to the initial value, the spatial and time periods of acceleration will be completed and the process of acceleration can be conducted in the next period.

Thus, in the linear collective accelerator the electron beam generating high-frequency oscillations and the accelerating proton beam are combined.

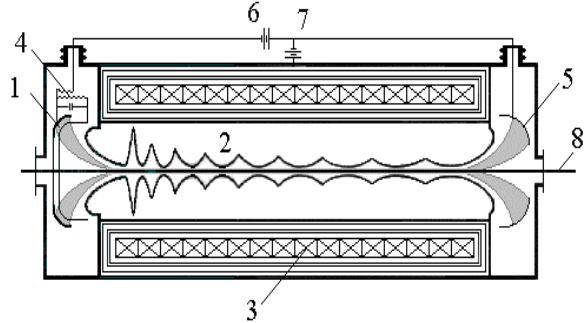

Fig. 4.

In Fig. 4 such an accelerating section designed for operation in the continuous mode is shown. It comprises the electron gun with monitoring grid 1, accelerating system 2, superconducting focusing solenoid 3, built - in vacuum system of self-modulation of EB density 4, the collector-recuperator of EB energy 5, and power supplies of the electron gun and the recuperator 6 and 7.

As is seen from Fig. 4 the construction of the accelerating section is such that permits to produce the ion beam acceleration in succession of placed one after another coaxial accelerating sections. As far as the method of acceleration under consideration allows to obtain phase velocities of accelerating waves equal to the light velocity then it is possible to accelerate protons up to energies of giga electron volts.

We have considered the variant of the linear collective accelerator, which is used to solve the most complex problem in the program of the electronuclear breeding, i.e the problems of the fuel material production.

The accelerator comprises the proton injector and 21 sections placed one after another shown in Fig. 4. Parameters of these sections are given in the following table (all accelerating sections are identical in arrangement but differ by the electron beam modulation frequency).

Table of parameters of accelerating sections

Number of section	Energy range of protons	Length m	Modulation frequency	Comments
1.	2.	3.	4.	5.
1	0.25-4	4	350	In all the sections:
2	4-16	5	700	- the electron energy of 0.5 MeV,
3	16-64	10	1400	- the electron current 2.2 μ A
4	64-128	13	2800	- guiding magnetic field 7.0 tesla
5	128-180	11	-//-	- electron efficiency of section 90%
6	180-230	10.5	-//-	in the presence of the system
7	230-280	10.5	-//-	of electron current recuperation
8	280-330	10.5	-//-	

1.	2.	3.	4.	5.
9	330-380	10.5	-//-	
10	380-43-	10.5	-//-	
11	430-480	10.5	5600	
.....	
19	830-880	10.5	-//-	
20	880-940	10.5	-//-	
21	940-1000	10.5	-//-	

The accelerator has: total length of 216 m, efficiency >50%, current of accelerated protons 0.3 A, total power of the proton beam 300 MW.

On this principle it is expedient to build subsidiary accelerators of the energetic complex, i.e., the accelerator driving reactors and proton accelerators for transmutation of long-living radioactive waste.

Estimating prospects of developing this method of acceleration it should be noted the following:

1) Problems of formation, modulation of dense EB and subsequent effective recuperation of its energy are urgent for a number of applications, i.e. such as the development of powerful amplifiers and electromagnetic oscillation generators using EB for cooling the ion beams, electron-ray generators of multicharged ions (ERMI). Therefore any progress in these fields may be useful for the realization of the method under consideration.

2) Development of superconductivity permits to generate stronger and stronger magnetic fields at higher temperatures. The progress in this field is very important for competition of the method.

3) The above-mentioned nearness to ERMI allows to expect that in the future it will be possible to join these devices in one accelerator of multicharged ions especially if to take account that our system gives the possibility to realize the selective extraction from ERMI ions of a necessary charging.

4) As was mentioned above the characteristic peculiarity of the method is presence of very strong radial focusing fields. It permits to generate ion beams of high density that is very important for practical applications.

5) The electric field intensity in the accelerating devices described may be increased by two or three orders of magnitude when one begin to work with pulses of $(5-10) \cdot 10^5$ eV energy with duration of hundreds nanoseconds and pulsed magnetic field of tens Tesla.

Among the papers done in this direction it should be noted the work in which accelerated 200 keV protons and pulse amplitudes of accelerated current of

0.1-0.15 A were obtained and also the works in which the method of ion acceleration with spatial harmonics of the charge density waves was investigated. Here we used not the corrugated liner and homogeneous magnetic field but the homogeneous liner and a spatial periodic magnetic field.

In other papers accelerated ions of nitrogen with the energy of 5 MeV and current to 15 A of duration of 100 mns were obtained with this method used EB of the energy of 280 keV and current of 3 kA.

However in these works basic reserves of increasing intensity of an accelerating field that is the transverse compression of EB and strong magnetic field were not used.

REFERENCES

1. L.A.Dushin, N.A.Khizhnyak, Applying the recuperation in linear accelerators // *Ukrainskij Fizi-cheskij Zhurnal*, 1957, v. 2, p. 106-114.
2. K.D.Sinel'nikov, P.M.Zeidlits, A.M.Nekrashevich, L.I.Bolotin, Ya.S.Shutskever, B.S.Akshanov, N.E.Kovpak, K.A.Leontovich, A.I.Akhiezer, I.M.Lifshits, Ya.B.Fainberg, L.N.Rozentsveig, G.Ya.Lubarsky, M.I.Kaganov, L.E.Pargamanik. Linear 20.5 MeV proton accelerator // *Proc. of AN UkrSSR Session on peaceful use of atomic energy*. Kiev, 1958, p. 5-15.
3. *Theory and calculation of linera accelerators* / Ed. by Acad. A.K.Valter, Moscow: Fizmatgiz, 1962.
4. V.V.Belikov, A.G.Lymar', N.A.Khizhnyak, Ion acceleration using the electron flow modulation // *Pis'ma v Zhournal Eksperimental'noj i Tekhnicheskoy Fiziki*. 1975, v. 1, No 13, p. 615-618.
5. G.G.Aseev, A.G.Korostelev, G.G.Kuznetsova, A.G.Lymar', P.A.Martynenko, N.A.Khizhnyak // *Proc. of XI All-Union Meeting on charged particle acceleration*, Dubna, 1985, v. II, p. 203-206.