

# CHOICE OF PARAMETERS FOR TESLA TRANSFORMER OF PULSED POWER BEAM GENERATOR TYPE

V.A. Kolchanova, G.V. Nosov, A.V. Petrov, Yu.P. Usov  
 Nuclear Physics Institute at Tomsk Polytechnic University,  
 Lenin Str. 2a, Tomsk, 634050, Russia  
 Phone: 7-3822-423989,  
 Fax: 7-3822-423934,  
 E-mail: usov@npi.tpu.ru

The accelerating voltage pulse generators of relativistic electron beams and high-power ion beam accelerators are subdivided into two main types: Marx generators and Tesla transformer type generators. In presented paper the attempt to create the methodology of the engineering substantiation of parameters and designing the Tesla transformer type generator for pulsed power accelerators is undertaken.

PACS numbers: 29.27.Ac

## 1 INTRODUCTION

Forming of accelerating voltage pulses of high-current accelerators of relativistic electrons or (by changing polarity) high-power ion beams is made in some stages [1]. The energy accumulation and high-voltage pulse generation is carried out with the help of Marx generators, and power magnification and temporary compression of pulse is realized with the help of pulse-forming lines.

For accelerators with not extreme high parameters of beams representing interest for solution of a lot of scientific and applied problems one applies successfully also primary accumulators on the base of resonance Tesla transformer-type generators [2].

The main advantages of the Tesla transformer generator as compared to the Marx generator consist in the following.

1. Possibility to work with rather high pulse-recurrence frequency.
2. Lower cost due to a small number of used high-voltage capacitors, diminution of weight and dimensions.
3. Magnification of reliability and resource (safe life) because of the absence of large number of spark switches.
4. Possibility to apply commercial standard switchboards in the primary contour of the Tesla transformer.

These arguments were taken into account when upgrading the "TONUS" accelerator [3]. This accelerator was started in operation 30 years ago with the Marx generator as a primary energy accumulator.

## 2 THE METHODOLOGY OF DESIGNING

The methodology of the technical substantiation of parameters and designing the Tesla transformer generator we have used to replace the Marx generator was the following.

It is known [4], that the choice of parameters of the transformer and coordination of these parameters with a capacitance  $C_1$  of the primary contour, in which the primary accumulation of the energy is carried out, and capacitance of forming lines  $C_2$ , Fig. 1, is determined by

the accelerator efficiency.

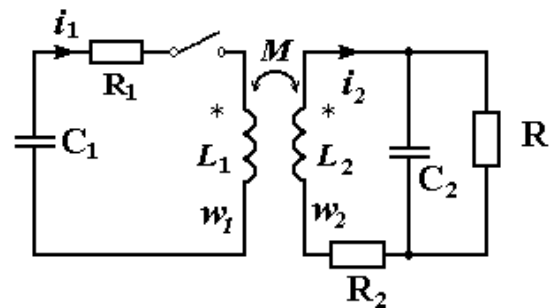

Fig. 1. Electrical schematic of the Tesla transformer.

In Fig. 1:  $C_1$  - primary energy storage capacitance;  $C_2$  - capacitance of the pulse forming lines;  $R$  - resistance of pulse forming line insulation;  $L_1, L_2$  - inductance and  $R_1, R_2$  - resistances of primary and secondary contours,  $w_1, w_2$  - number of coils, of primary and secondary windings, respectively;  $M$  - mutual inductance of two contours.

So, it is considered, that for a charge of lines it is necessary to have a coupling coefficient between windings of the transformer accordingly to

$$K = M(L_1 L_2)^{1/2} = 1; 0,6; 0,385.$$

Frequencies of free oscillations in primary and secondary contours of the transformer should be identical, i.e.

$$f_1 = \frac{1}{2\pi\sqrt{L_1 C_1}} = \frac{1}{2\pi\sqrt{L_2 C_2}} = f_2.$$

The package of computer programs for calculation and optimization of parameters of the transformer was developed in view of active power losses in primary and secondary contours.

Differential equations for voltages and currents of contours were calculated numerically under the standard programs, and the parameters of the transformer with cylindrical or conic windings are determined under the special program of magnetic field calculation.

The program is realized in the following sequence:

- input of basic data ( $C_1, C_2, K, U_{c1max}, U_{c2max},$
- $i_{1max}$ , time of  $C_2$  charging),

- determination of the transformer parameters ( $L_1$ ,  $L_2$ ,  $M$ , number of coils  $w_1$ ,  $w_2$  and sizes of windings),
- calculation of voltages and currents in contours as a function of time without active losses,
- determination of the cross-section of winding wires, their active resistances, and also the resistance  $R$ , taking into account a self-discharge of a capacity  $C_2$ ,
- calculation of voltage losses, currents, energy and efficiency of its transfer.

The experimental results obtained by putting into operation the accelerator "Tonus-NT" and results of calculation under the given program differ no more, than by 10%.

### 3 CONCLUSION

On the base of computer simulation analysis it is possible to make the following conclusions:

- The most effective work of the transformer is realized for  $K \approx 0.7$ , when the capacity  $C_2$  is charged on the second half-wave of voltage, efficiency achieves 80%.
- Most effective is the transformer, at which the coaxial conic and cylindrical winding are displaced from each other on some span defined by parame-

ters.

- The accessible amplitude of a high voltage is more sensitive to set-up of resonance frequencies of primary and secondary contour, rather than to mutual inductance between contours.

### REFERENCES

1. A.N.Didenko, V.P.Grigoryev, and Yu.P.Usov. High-power electron beams and their application. Moscow: Atomizdat, 1977 (in Russian).
2. S.B.Vasserman. Preprint 77-110, Institute of Nuclear Physics of Siberian Branch of USSR Academy of Sciences, Novosibirsk, 1977, 43 p (in Russian).
3. I.Z.Gleizer, A.N.Didenko, Yu.P.Usov et al. // *Atomnaya energiya*. 1974, v. 34, no. 5, p. 378 (in Russian).
4. S.P.Bugayev, A.S.El'chaninov, F.Ya.Zagulov, B.M.Koval'chuk, G.A.Mesyats, and Yu.F.Potalitsyn. In "High-power nanosecond pulsed sources of accelerated electrons", Novosibirsk, 1974, p. 113 (in Russian).