

KIJASHKO-PIKOVSKY-RABINOVICH NOISE GENERATOR: COMPUTER SIMULATION AND EXPERIMENT

I.O. Anisimov, A.V. Schur, T.V. Siversky

*Taras Shevchenko National University of Kyiv, Radiophysics Faculty, Kyiv, Ukraine,
ioa@univ.kiev.ua*

Characteristic regimes of Kijashko-Pikovsky-Rabinovich (KPR) noise generator were investigated on the basis of analytic theory and numerical simulation. Previously unknown regimes were found out. Modified circuit of KPR noise generator using the operational amplifiers was developed. Signal waveforms were measured. Several regimes of KPR noise generator predicted by simulation were experimentally verified. Especially the relaxation regimes for large gain factors of the operational amplifier were obtained.

PACS: 52.35.Mw

1. INTRODUCTION

Kijashko-Pikovsky-Rabinovich (KPR) noise generator (fig.1) is one of the simplest systems that can demonstrate stochastic dynamics. Consequently this system can be widely used for the preliminarily acquaintance with such systems [1-2].

One of the stochastic regimes of KPR noise generator was experimentally investigated in [3]. The simple analytical theory that describes this regime and its statistics was proposed in [4]. Only the tunnel diode non-linearity was taken into account in this theory.

Modified set of differential equations taking into account the non-linearity of an active amplifier element and piecewise-linear approximation of the tunnel diode volt-ampere characteristic (VAC) was proposed for the description of the KPR noise generator in [5]. This set was solved numerically. Two new regimes of the stochastic oscillations and two relaxation regimes were found out. Corresponding diagram of the regimes depending on two driving parameters was obtained.

Further investigations estimated several bifurcation parameters of the KPR generator, i.e. described the domain boundaries of the KPR generator characteristic regimes.

Regimes predicted in [5-6] were not observed in the experiment [3] because it was impossible to vary the parameters of the original circuit over a wide range. Of course, computer simulation had no such limitation.

Results of the experimental investigation of the modified KPR noise generator based on the operational amplifier are described in this article. Experimental verification of several regimes predicted in [5-6] is obtained.

2. MODIFIED THEORY OF KPR NOISE GENERATOR

The electrical circuit of KPR noise generator is given on fig. 1. This circuit is described by the following set of equations [5-6]:

$$\begin{cases} di/d\tau = (\gamma - u^2)i - v - u; \\ du/d\tau = i; \\ \varepsilon dv/d\tau = i - i_d(v). \end{cases} \quad (1)$$

Here

$$v = V/U_{\infty}; \quad u = U/U_{\infty}; \quad i = \rho I/U_{\infty}; \quad \tau = t\omega; \quad \varepsilon = C_1/C;$$

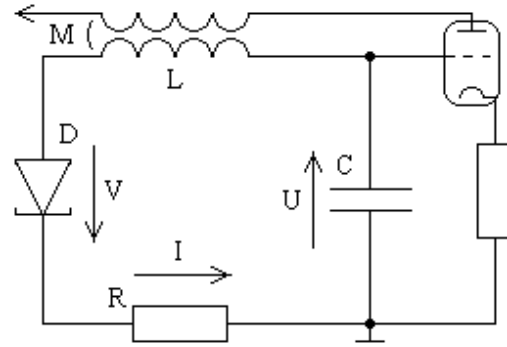

Fig. 1. Electrical circuit of KPR noise generator

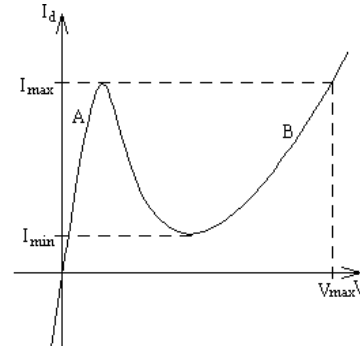

Fig. 2 VAC of tunnel diode

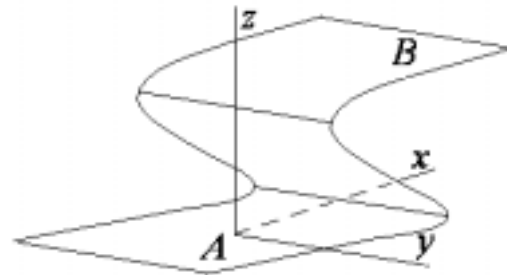

Fig. 3 Surfaces of the slow motion on the phase portrait of KPR generator

$$\begin{aligned} \gamma &= K^2/U_{\infty}^2 - R/\rho; \quad v_1 = V_1/U_{\infty}; \quad r_A = R_A/\rho; \quad r_B = R_B/\rho; \\ \omega^2 &= 1/LC; \quad \rho^2 = L/C; \quad U_{\infty}^2 = K^2/\omega MS, \end{aligned} \quad (2)$$

values I, U, V, R, L, M, C are shown on fig.1, C_1 is the junction capacitance of tunnel diode, S is the slope of the triode transfer characteristic approximated by cubic polynomial

$$I_a = SU - SU^3/3K^2,$$

$i_d(v)$ is VAC of tunnel diode approximated by the

piecewise-linear dependence

$$i_d(v) = \begin{cases} v/r_A, & v < v_1; \\ (2v_1 - v)/r_A, & v_1 \leq v < 2v_1 r_B / (r_A + r_B); \\ v/r_B, & v \geq 2v_1 r_B / (r_A + r_B). \end{cases} \quad (3)$$

For $\gamma < r_A$ the amplitude condition for self-excitation is not satisfied. So solution of the equations' set (1) is quasi-linear damped oscillation. When γ exceeds the critical value r_A (i.e. the amplitude condition for self-excitation satisfied) Andronov-Hopf bifurcation takes place and thus quasi-harmonic continuous oscillations are installed.

With the further increase of γ when the magnitude of the steady oscillations (for the linear resistor used instead of the tunnel diode) exceeds i_{max} , i.e. for $2(\gamma r_A)^{1/2} > v_1/r_A$, the signal waveform qualitatively changes and stochastic regime appears. When the current in oscillatory circuit exceeds i_{max} the jump from low-resistance increasing brunch A to the high-resistance one B occurs (fig.2-3). So the ohmic resistance abruptly increases (voltage drop across the tunnel diode increases while the current through diode does not change). It results to the aperiodic damping in the oscillatory circuit. After the current magnitude decreases to the value i_{min} , the jump from brunch B to brunch A takes place. The new package of oscillations with new amplitude and phase is generated, because the probability to get to the previous phase trajectory vanishes [3-4]. This regime can be referred as monomodal one because it corresponds to the monomodal mapping.

With the further increase of γ the oscillations' increment grows. So the representative point during one rotation can perform several couples of jumps between the surfaces A and B (fig 3.). Thus the new stochastic regime appears. It differs from the one described above. It can be referred as multimodal regime because it corresponds to the multimodal mapping [5].

For very large γ the oscillations' voltage magnitude becomes much more then the non-monotonic interval of the tunnel diode VAC. So this interval becomes inessential and system generates the relaxation-type oscillations similarly to the Van-der-Pole generator.

3. RESULTS OF KPR GENERATOR NUMERICAL SIMULATION

Numerical solution of the set (1) allows us to investigate the behavior of the KPR noise generator depending on the driving parameters γ and v_1 . The appropriate diagram of the characteristic regimes based on the analysis of the obtained signals' waveforms was built (fig. 4.). These regimes can be pointed out: 1 – damped oscillations; 2 – quasi-harmonic oscillations; 3 – monomodal stochastic regime; 4 – multimodal stochastic regime; 6, 7 – relaxation regimes (fig. 5 a).

Fig. 5 b demonstrates another type of the multimodal stochastic regime (regime 5). Its representative point performs one and only one couple of jumps between the surfaces of slow motion A and B. Quasi-harmonic oscillations occur for this regime. The oscillations' magnitude varies randomly from one period to another.

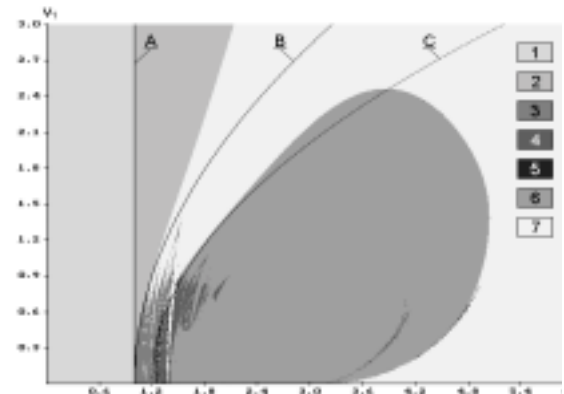

Fig. 4. Diagram of KPR generator regimes in (γ, v_1) coordinates 1 – damped oscillations; 2 – quasi-harmonic oscillations; 3,4,5 stochastic regimes; 6,7 – relaxation regimes

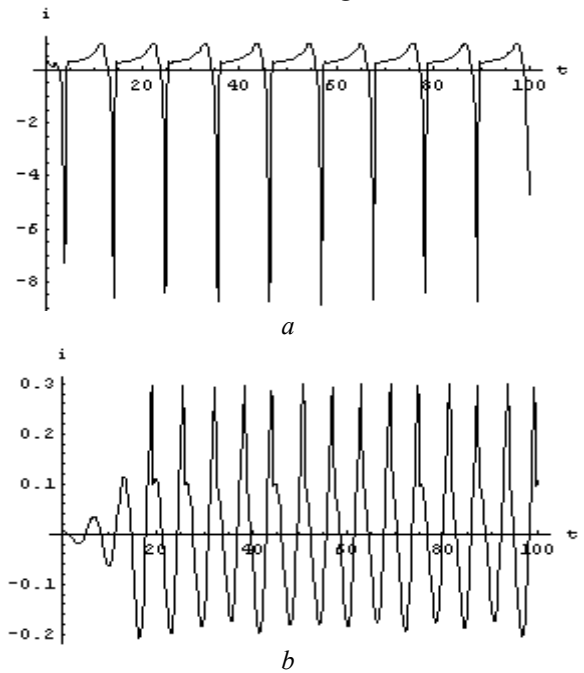

Fig.5. Relaxation (a) and multimodal stochastic (b) oscillation regimes

The hysteresis i.e. the signal waveform dependence on the initial conditions was noticed for the driving parameters corresponding to the boundaries between the different regimes.

4. ELECTRICAL SCHEMATIC DIAGRAM OF THE MODIFIED KPR NOISE GENERATOR

It was already noticed that many parameters (gain factor, non-linearity of amplifier, Q-factor, etc) of the KPR noise generator given on fig. 1 can not be varied over a wide range. The modified electrical schematic diagram of the KPR noise generator (fig. 6) is proposed. Operational amplifier is used in this circuit instead of radio tube. For convenient data processing ADC and computer were used. So the oscillation frequency and it's harmonics should not exceed the upper frequency limit of available ADC (24 kHz). Under this circumstances high Q-factor values are unreachable because of the high resistance of the inductance coil at low frequencies. That's why equivalent gyrator circuit was used instead of the inductance coil. Consequently the

value of Q-factor of about 10^3 could be reached. The oscillatory circuit was moved from the feedback circuit to the load circuit. The modified KPR noise generator allows varying many parameters (gain factor, nonlinear characteristics of feedback loop, the current over tunnel diode, and Q-factor) in the wide range.

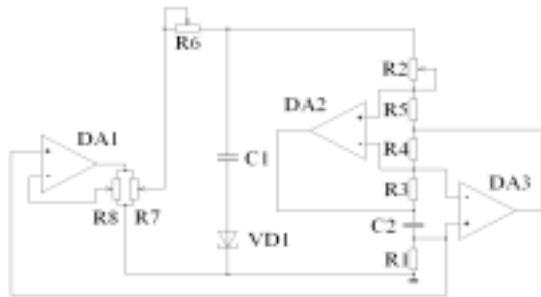

Fig 6. Modified circuit of the KPR noise generator.
 $R1, R3, R4, R5=560\Omega$, $R6=1.5M\Omega$, $R7=10k\Omega$,
 $R8=47k\Omega$, $R2=1.5k\Omega$, $C1-C2=1mkF$, DA1-DA3 –
 LM101A

The KPR noise generator is based on the gyrator circuit that consists of the following elements: DA2, DA3, R1, C2, R3, R4, and R5. It has the parallel connection with the tunnel diode VD1 and the capacitor C1. These elements form the high-Q oscillatory circuit for small signals because the resistive component of impedance of this circuit depends only on the value of R2. A source of the feedback signal of the oscillatory circuit is resistor R1. Then it is amplified by DA1. The feedback resistor R8 allows varying the gain factor and non-linearity. The output of DA1 is connected with the potentiometer-type voltage divider R7. It linearly decreases the generator feedback voltage. Resistor R6 completes the feedback loop. It varies the current over the load oscillatory circuit. The signal waveforms were taken using the dual-channel ADC Philips UDA1361T (CNR=88 dB, THD+N=83 dB, sampling rate is 48 kHz). Waveforms taken from resistor R2 represent current in the oscillatory circuit.

5. EXPERIMENTAL INVESTIGATION OF THE MODIFIED KPR NOISE GENERATOR

For the low feedback factors the damping quasi-harmonic oscillations were observed.

Some increase of the feedback factor caused the generator self-excitation. The magnitude of obtained oscillations (voltage on oscillatory circuit) was about 1V less than the power supply voltage (15 V).

Further increase of the feedback factor caused the stochastic regime appearance (described in [3-4]). One could observe the bursts of up to 50 oscillations due to the high Q-factor.

Further increase of the feedback factor resulted to the establishment of the periodic relaxation-type oscillations. The signal waveform and spectrum for this regime are given on fig. 7. The first harmonic is 141 ± 1 Hz.

In the narrow band of parameters one of the multimodal stochastic regimes similar to the regime 5 (see fig. 4 and fig. 5b) was observed. The corresponding waveform and its spectrum are presented on fig. 8.

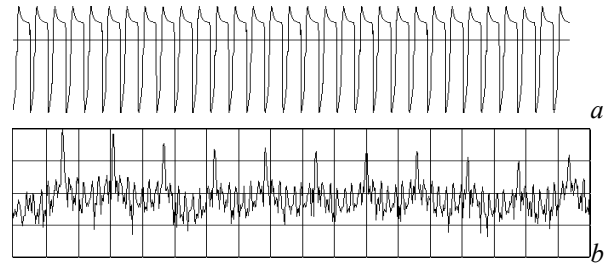

Fig 7. Relaxation oscillation regime: waveform of current in oscillation circuit (a) and its spectrum (b)

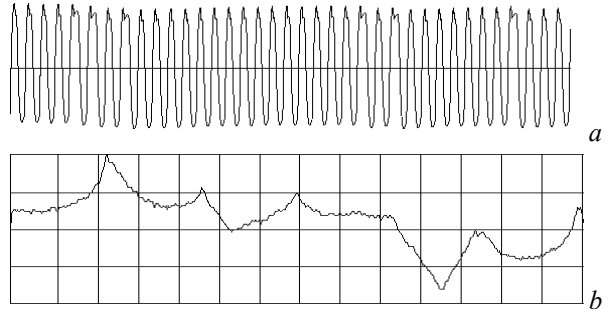

Fig 8. Multimodal stochastic regime: waveform of current in oscillation circuit (a) and its spectrum (b)

6. CONCLUSION

Modified circuit of the KPR noise generator giving the possibility to vary several parameters in the wide range is proposed. Its behavior was investigated experimentally. Some regimes predicted by the modified theory of KPR noise generator [5-6] were observed, i.e. one of the multimodal stochastic regimes and relaxation-type oscillations. Bifurcation chain caused by the gain factor varying predicted by this theory was also observed.

Some difference between the results of experiment and theory can be explained by taking into account the difference between the experimentally investigated scheme and one being simulated.

REFERENCES

1. M.I. Rabinovich, D.S. Trubetskov. *Introduction to the theory of waves and oscillations*. Moscow: "Nauka", 1985. (In Russian).
2. I.O. Anisimov. *Oscillations and waves*. Kyiv: "Academpress", 2003. (In Ukrainian).
3. S.V. Kiyashko, A.S. Pikovsky, M.I. Rabinovich. Self-generator of the radio band with the stochastic behavior // *Radiotekhnika i elektronika*. 1980, v. 25, №2, p. 336-343. (In Russian).
4. A.S. Pikovsky, Stochastic oscillations in dissipative systems // *Physica*. 1981, v. 2D, p.8-24.
5. I.O. Anisimov, A.M. Didovyk, T.V. Siversky. Modified theory of the Kiyashko-Pikovsky-Rabinovich noise generator // *Bulletin of Kyiv University. Physics and Mathematics*. 2000, issue 2, p. 367-374. (In Ukrainian).
6. I.O. Anisimov, T.V. Siversky. Bifurcations in the Kiyashko-Pikovsky-Rabinovich noise generator // *Bulletin of Kyiv University. Radio physics and electronics*. 2002, issue 4, p. 12-19. (In Ukrainian).